

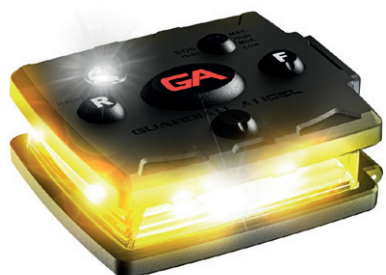

BodyLED micro safety lamp



Item no. 860986



Item no. 860987

IP67

Technical Data

Electric power supply:	Lithium polymer rechargeable battery: 500mAh (1'500 to 3'000 charging cycles)
Charging time to full charge:	0.4h
Luminous period (all LEDs):	
– blinking mode:	
– MAX:	1.30 h
– high:	2.15 h
– middle:	4.15 h
– low:	>11 h
– Volllicht:	
– MAX:	0.25 h
– high:	0.30 h
– middle:	0.50 h
– low:	6h
Protection category:	IP67
Equipment:	11×LED (colours depend on the version)
Casing:	Reinforced glass fibre polycarbonate with integrated magnetic attachment system
Magnet type:	Neodym, 9kg tensile strength NB42 quality
Temperature range:	–40° C to +110° C
Dimensions (l×h×p):	53×45×23 mm
Weight:	57g
Flammability rating:	UL746B, UL94
Scope of delivery:	1 BodyLED Micro safety lamp 1 USB-C charging cable 1 attachment system

Product features

- visibility from very long distances – up to 3 kilometres due to high-power LEDs, 360° illumination
- discrete work light function – single red LED mode for low-light environment (no glare)
- four different brightness settings – low, medium, high and MAX
- SOS light function
- rechargeable lithium-ion battery with USB-C cable
- battery charge level - indication at the touch of a button
- integrated magnetic attachment system – the neodymium magnet and magnetic clip (included) can be attached to almost any surface
- intermittent flashing or continuous light – the front and back of the light can also be used simultaneously or separately
- independent light control – 4 different control buttons which provide a variety of lighting options, including an emergency mode (flash)
- protection class IP67 – resistant to water, dust and shocks

Item no.	Description
860986	BodyLED Micro safety lamp, white/yellow USB-C charging cable and attachment system incl.
860987	BodyLED Micro safety lamp, yellow/yellow USB-C charging cable and attachment system incl.

Accessories/spare parts

860932	Magnetic clip
860953	Belt attachment
860954	Bicycle/pipe rubber holder

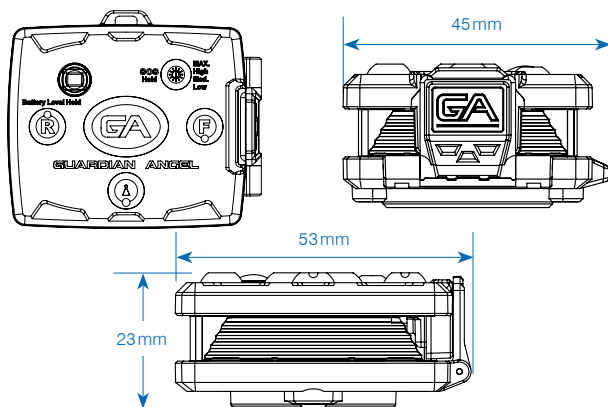

Item no. 860932

Item no. 860953

Item no. 860954

✓ from stock, offer subject to prior sale

1/1